

CVO-5 DOUBLE UP PACKAGE

- 10 CUBIC FT OVEN SPACE
- MINIMAL MOBILE FOOT PRINT
- OPTIMIZED PURGE CONNECTIONS
- NRTL CERTIFIED

Ideal for large volume production with the flexibility of small batch management.

Two CVO-5 vacuum ovens powered by a single Agilent IDP15 9 cfm oil free scroll pump.

High production, clean vacuum drying or purging with deep vacuum and large offgas loads.

PACKAGE INCLUDES

- 2 each CVO-5 Vacuum Ovens
- 10 Total Shelves (16 max)
- 1 each Agilent IDP15 9 CFM Scroll Pump
- 1 each Industrial Mobile Rack with Two Shelves
- MAX EVAP KF-25 Connection Kits

FEATURES

Temperature probe INSIDE of oven for accurate readings

Reduced purge times with MAXEVAP connections

Bright LED lights & tempered safety glass viewing window

Touchscreen Microprocessor Control

Digital Vacuum Gauge

Solvent resistant BUNA-N door gasket

Easy-Turn Valves



COMPLETE VACUUM PURGE SYSTEM

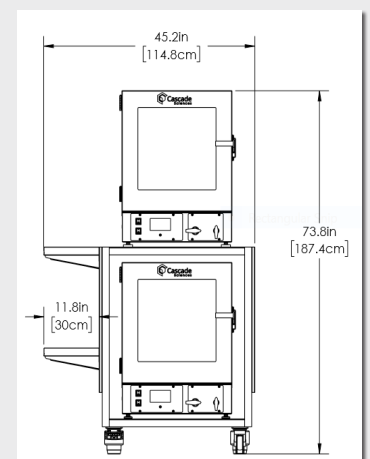
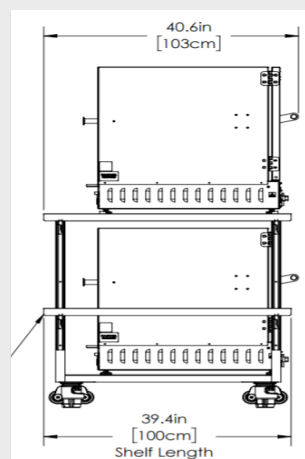

Visit our showroom!

6725 NE Evergreen Pkwy, Ste 106
Hillsboro, OR 97124



(503) 847-9047

info@cascaDESCIENCES.com
cascaDESCIENCES.com

© 2018 Cascade Sciences, LLC

SPECIFICATIONS



NRTL CERTIFICATION

CAN/CSA-C22.2 No. 61010-1:2012
+ UPD No. 1:2015-07 + UPD No. 2:2016-04
CAN/CSA-C22.2 No. 61010-2-010:2015
UL 61010-1:2012/R:2016-04
UL 61010-2-010:2015
EN 61010-1:2010



NRTL CERTIFICATION

IEC 61010-1:2010 / EN 61010-1:2010 Canada:
CSA C22.2 No. 61010-1-12 USA:
UL Std. No. 61010-1 (3rd Edition)



CVO-5 VACUUM OVENS

CAPACITY

Volume: 4.5 Cubic Ft/127 litres
Interior: 18.25" W x 24" D x 18.25" H
Exterior: 25" W x 30.5" D x 30.5" H

SHELVING

5 Each. Adjustable
8 Max
Surface Area: 18"W x 24"D
Weight Capacity: 50 lbs

TEMPERATURE

Stability: $\pm 0.4^\circ$ @105°F
Uniformity: +1.5° @ 105°F
Low Temp Range: to 250°F / 121°C

CONNECTIONS (INCLUDED)

Vacuum: 3/8" barb
Vent: 1/4" barb
KF-25 Port (1" Dia) YES
MAXEVAP Full KF-25 lines, valve &
Connection: exit port

WEIGHT

Oven/Pump: 360 lbs / 75 lbs
Shipping: 961 lbs

AGILENT IDP15 9CFM SCROLL PUMP

PERFORMANCE

Pumping 9cfm
Speed at 60Hz: 213 L/m, 12.8 m3/hr
Ultimate Pressure: 10×10^{-3} Torr (13.3×10^{-3} mbar)
Gas Ballast: 1/4" NPT
Position 1: 20.7 g/hr water vapor (installed)
Position 2: 235 g/hr water vapor

CONNECTIONS (INCLUDED)

Inlet: KF-25
Exhaust: KF-16

DIMENSIONS

19.2" D x 14.33"H x 9.5"W

FACILITY SPECIFICATIONS RECOMMENDED SYSTEM CIRCUITS

120V Configuration:

3 each 120V / 1 pH / 20AMP Circuits

220V Configuration:

2 each 220V / 1pH / 20AMP Circuit

Optional 1 each 120V / 1pH for future cold trap, ancillary equipment or
to run pump on 120V

CVO-5/TVO-5 VAC OVENS

10-120V / 1pH 14A 50/60Hz

Cord included
NEMA 5-15 power outlet

220V-240V / 1pH / 7A 50/60Hz

Cord included
NEMA 6-15R power outlet
(System will run on 208V)

AGILENT IDP15 PUMP

220V-230V / 1PH / 3AMP

120V / 1pH / 5AMP
*m/sec AMP surge
at start up

Noise Level:

50dBA +/- 2dBA

Operating Temp: 41°F-104°F / 5°C-40°C

Visit our showroom!

6725 NE Evergreen Pkwy, Ste 106
Hillsboro, OR 97124



(503) 847-9047

info@cascadesciences.com

cascadesciences.com

© 2018 Cascade Sciences, LLC