

CVO-10 PRO PACKAGE

Vacuum Purge with -50°C Cold Trap

SHORT LEAD TIMES
GET IN BUSINESS FASTER!



Cascade's CVO-10 PRO Package with MAXTRAP50 is a complete vacuum drying system designed for temperature sensitive, high-thru-put for vacuum purging large production quantities.

FEATURES

- Temperature Range: Ambient +26°F to 302°F / Ambient +14.4°F to 150°C Temperature Uniformity:
 - @ 105°F +/-2°F
 - @ 200°F +/-5.5°F
 - @ 300°F +/-8°F
- Touchscreen temperature readout with temp sensor INSIDE the oven
- VITON door gasket
- LED window lights for visibility of material
- Digital vacuum gauge reads in inches of mercury, Torr, and mTorr
- Smooth, quarter-turn vent valve
- Rear KF-25 port includes MAXEVAP Connection Kit for rapid vacuum drying or running feedthroughs inside oven for monitoring
- 220V / 1ph / 10AMPS NEMA 6-15R Plug
- Quality Tempered Rated Glass NGI-US to ANSI Z97.1.2007 156CFR/201 11 SGCC -2577 ½ UA
- Fast venting with larger ½" diameter vent line also allows for nitrogen or other inert gas connection
- Touch Panel LED control screen with user settable features, easy updates
- Mobile on heavy duty casters
- NRTL Certified Components

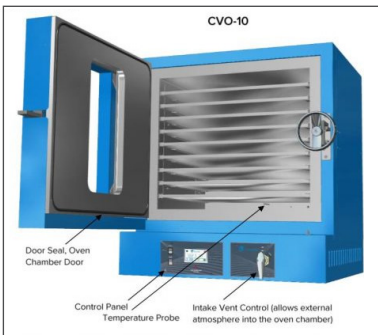

CVO-10 PRO PACKAGE INCLUDES

AGILENT VACUUM PUMP
IDP15 Oil-Free Scroll Pump, 9 CFM

CASCADE'S MAXTRAP50
-50°C Cold Trap

MAXEVAP CONNECTION KIT
Maximize Vapor Exit Path

MOBILE RACKING
Easily mobile with heavy duty swivel casters

503-847-9047
info@cascadesciences.com
cascadesciences.com

VISIT OUR SHOWROOM!
6725 NE Evergreen Pkwy, Ste 106
Hillsboro, OR 97124

CVO-10 PRO Package with MAXTRAP50

SPECIFICATIONS



AGILENT IDP15 VACUUM PUMP

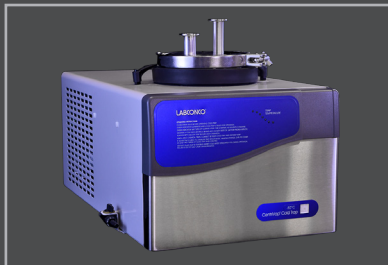

MAXTRAP50



MAXEVAP CONNECTION KIT

CVO-10 VACUUM OVEN

Item No	CVO-10-ProTrapPKG
Temperature Range	Ambient +26° to 302°F / Ambient +15° to 150°C
Volume	9.3 Cu Ft (263L)
Vacuum Gauge	Reads in inches of mercury, Torr, or mTorr
Controller	Touch screen, accurate within 1°F
Power	220V - 240V / 1ph / 10AMP (50/60Hz)
Exterior Dimensions	42"W x 40"D x 67.4"H (not including mobile cart)
Interior Dimensions	28"W x 24"D x 24"H
Weight	Shipping: 775lbs / Net Weight: 663lbs
Shelves	9 Total (max), removable, integrated copper strips optimize temp transfer
Surface Area	28"W x 24"D
Weight Capacity Per Shelf	50lbs
Volume	Approx 930 Cu In

NRTL Certified Components

VACUUM PUMP - AGILENT IDP15 OIL-FREE SCROLL, 9CFM

Ultimate Pressure	45°C to 200°C
Power	±0.02°C
Intake Connection	KF-25
Dimensions	19.08"L x 9.22"W x 14.3"H
Weight	75lbs
Mobility	Sits on Mobile Cart

NRTL Certified Components

-50°C COLD TRAP - CASCADE SCIENCES MAXTRAP50

Capacity	3 Qt (2839mL)
Gasket	Viton
Insulator Cap	Neoprene
Power	115V / 1ph / 4 AMP (60Hz), includes cord
CFC / HCFC Free Refrigerants	
MAXTRAP50 Dimensions	13.5"W x 23.5"D x 12.0"H
Mobile Cart Dimensions	32"L x 32"W x 40"H

Included Connections	1 each 4' KF-25 flanged vacuum rated line 1 each KF-25 Centering Ring 1 each KF-25 Clamp
-----------------------------	--

NRTL Certified Components

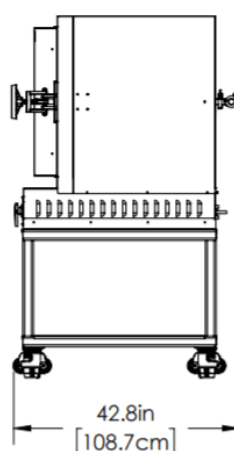

Side view

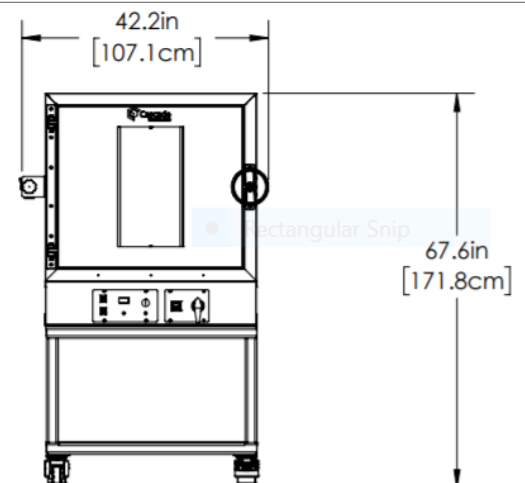

503-847-9047

info@cascadesciences.com
cascadesciences.com

VISIT OUR SHOWROOM!

6725 NE Evergreen Pkwy, Ste 106
Hillsboro, OR 97124