











■ SAFETY PRECAUTIONS

◆ Safety symbol used in the manual

| | |
|--|---|
| <p>Danger</p>  <p>The exclamation point within an equilateral triangle is intended to alert the user to the presence of important operating and maintenance instructions in the literature accompanying the appliance.</p> | <p>Dangerous voltage</p>  <p>The lightning flash with arrowhead symbol, within an equilateral triangle, is intended to alert the user to the presence of uninsulated "dangerous voltage"</p> |
| <p>Explosion hazard</p>  <p>If volatile and explosive chemical materials are used, the explosion may occur.</p> | <p>High temperature</p>  <p>Be careful not to use at high temperature.</p> |
| <p>Notice</p>  <p>If the user arbitrarily dismantles or transforms the product, the fatal damage of the product may be induced.</p> | <p>Approach prohibition</p>  <p>Prohibit the user from approaching to this area.</p> |
| <p>Warning</p>  <p>If the product is mishandled while ignoring this symbol, the danger by which human beings are dead or severely injured may occur.</p> | <p>Contact prohibition</p>  <p>Prohibit the contact at the moment that leads to the accident.</p> |
| <p>Caution</p>  <p>If the product is mishandled while ignoring this symbol, the possibility in which human beings are injured or property damage occurs exists.</p> | <p> Observe the safety rules.</p> |
| <p> Be careful to maintain the horizontality of the product and not to fall to the ground.</p> | <p> Earth</p> <p> OFF position of power switch</p> <p> ON position of power switch</p> |
| <p> Keep the product out of the direct rays of the sun.</p> | <p>N Connection point of the neutral wire of installation</p> <p> AC voltage</p> |

WARNING :

TO PREVENT FIRE OR SHOCK HAZARD, DO NOT EXPOSE THIS APPLIANCE TO RAIN OR MOISTURE.



CAUTION
RISK OF ELECTRIC SHOCK
DO NOT OPEN



CAUTION : TO REDUCE THE RISK OF ELECTRIC SHOCK, DO NOT REMOVE COVER. NO USER SERVICEABLE PARTS INSIDE. REFER SERVICING TO QUALIFIED SERVICE PERSONNEL.

● **Precautions at transportation and installation**



- Please never tilt or lay the product down during transportation.
- Be careful not to drop when transporting the product.
- This product was manufactured to move normally at the rated voltage. Confirm the voltage state before the installation of product.



- Install the product in a place where the floor is hard and flat.
- Keep the set free from moisture, water and dust. It may cause overheating or short circuit. (Pollution Degree 2)
- Do not install the product in a location at an altitude of over 2,000 meters. (6,562 feet).



- Avoid high temperatures : Install the product out of the direct rays of the sun.
- When the product is moved, separate the power plug from a wall outlet, and then move not to damage the product. The cord damage becomes the root cause for an electric shock or an ignition.



- If the product was moved or stored in high humidity state, identify the packaging state of the product before use. In case that the carton box or wooden box is soaked in water, consult with an engineer about the matter. Do not operate the equipment before the safety is confirmed. This wetting state may be the cause of an electric shock or a fire.
- When installing and using the product, please certainly use the power cord provided with the products.

● **Precaution in use**



- Please be familiar with the user manual before using this product, and operation should be performed only by qualified personnel.
- This product must be used within the permitted standard load resistance.
- This product should be operated in a room with temperature maintain between 5°C and 40°C. Long-term use in an environment that exceeds the allowable range may cause a malfunction.



- Do not cut or process the power cord or do not bend it by force or pull or tie up it. In addition, if heavy things are placed on the power cord, it may cause damage and it may become the root cause of a fire or an electric shock.



- Please do not touch or manipulate the electrical parts such as the power plug with wet hands electric shock.
- Please do not operate the product by manipulation of the plug to avoid electric shock or short circuits.



- Do not operate the product in the outdoors. It is not allowed to use it at the place that is exposed to the sun or at the place that is gotten in the rain. This leads the product to overheating or electric malfunction.



- Do not use the product on a high place or at high temperature. Do not use the product near the heater or the wind of air conditioner. The accident by the overheating of the equipment can occur.



- Do not operate the equipment at the place of an inflammable danger or a fire danger. This triggers the severe accident such as an explosion or a fire.



- Please do not use the flammable spray such as lacquers and paint, or volatile, flammable chemicals and its similar product, in the proximity of the product. They may cause the ignition due to the spark of switch.
- If you detect any noise, which is unlike any other time, or it exhibits wrong movement symptom, immediately turn off the power of the product and separate the power cable from the body.
- Please regularly check whether dust or dirt are on the power plug and completely connect the plug. If the plug is covered with dust, or the connection is not complete, it will cause an electrical shock or fire.
- Please separate the power plug from the outlet for safety when the product is unused for long periods of time to avoid overheating or ignition due to dust.
- Please handle the power cord carefully. Hold the plug when unplugging the cord
- The fluctuation of main power voltage should be lower than +/-10% of the nominal voltage.
- The maximum relative humidity is 80% at 31°C and 50% at 40°C.

- Please maintain the clean condition of this product by removing the foreign matter while gently wiping with the neutral detergent and a dry cloth after checking whether the foreign matter present or not, before and after using this product.



- If unexpected sound, smell or smog is generated, pull the main plug out from the wa socket and contact the technical service center.



- Only operate unit after checking the safety of the unit.
- The Sound Level of the buzzer is maximum 60dB in 1 meter distance
- Please keep a human body away from this product when this product is operating at high temperature. Please use this product after wearing the protective equipment at high temperature.
- Be sure to separate the product from power supply code and cooled down it sufficiently before the transfer of the product to other place.
- Please wear the protective equipment because the heating temperature can be overheated above the setting temperature.
- Please always use the safety equipment (working clothes, gloves and safety glasses) when using this product.
- Please never cover with aluminum foil, etc. over the plate during the heating operation. It can result in the serious damage of the equipment due to overheating.
- Please do not install this product around the product having strong magnetic force.
- Please do not use this product in conjunction with a metal container.
- Do not put the product in places exposing to direct heat sources.
- Please be careful for burns because the residual heat may be remained even if this product is operating or the power was disconnected.

■ INTRODUCTION

Thank you for purchasing Hotplate Stirrer of SH Scientific Co., Ltd. We, SH Scientific Co., Ltd., started to manufacture and supply highly reproducible and reliable products in the basic equipment for basic science research such as biotechnology, medicine, environment, and chemistry. Especially, in various experimental equipment for various purposes, the accumulated know-how of SH Scientific Co., Ltd. has achieved high convenience and reliability by achieving commonization and systematization of the methods of use.

This product is manufactured as subminiature size for the effective use in customer's laboratory, and it guarantees low noise and low vibration to maintain the comfortable environment of laboratory. In addition, it was designed by adopting electrical and instrumental safety devices to realize the use safety. We, SH Scientific Co., Ltd. pursue customer satisfaction as the best value, We will do our best to implement steadily. Thank you.

TABLE OF CONTENTS

| | |
|--|----|
| 1. Before Using | 7 |
| 2. Features | 7 |
| 3. Product Installation | 9 |
| 4. Composition identification | 9 |
| 5. How to install | 10 |
| 6. Product specification..... | 12 |
| 7. Check before operation | 13 |
| 8. Product Structure | 13 |
| 9. Control Panel | 14 |
| 10. Operation | 15 |
| 11. Setting RPM | 15 |
| 12. Setting Operation Temperature..... | 16 |
| 13. Setting Temperature Offset | 17 |
| 14. Setting Timer | 18 |
| 15. Locking Mode | 19 |
| 16. Product management | 20 |
| 17. Regular inspection | 20 |
| 18. Cleaning and storage | 21 |
| 19. Troubleshooting | 22 |
| 20. Error identification | 22 |
| 21. Accessory | 23 |

1. BEFORE USING

Pay attention to the following before using this unit:

- **Moving the set**

To prevent short circuits or damaged wires in the connection cords, always unplug the power cord safely.

- **Before turning the power switch on**

Check once again that all connections are proper and that there are not problems with the connection cords.

- **About operating manual**

Read and understand all the instructions in the user manual before using the products.

In any case, we don't bear responsibility for the damage of product which occurs by no observance for the requirements of user manual. The contents of user manual may be changed or improved. Use only for the intended purpose which is described in the user manual. After reading, store this manual along with the warranty in a safe place.

- **Note that illustrations in this manual may differ from the actual set for explanation purposes.**

2. FEATURES







The high-temperature Hotplate Stirrer of SH Scientific Co., Ltd. is capable of heating up to the high-temperature of 400°C and powerful agitation based on strong magnetism. It also exhibits excellent thermal conductivity and chemical resistance and is applicable to various laboratories. Features of the product are as in the following.

- It can be safely used also in high temperature by applying the heat-resisting ceramic coated top plate.
- The upper plate has specially designed heat line and can offer proper temperature uniformity.
- The upper plate has a high chemical resistance and thus the maintenance thereof is easy.
- It has been manufactured considering the safety of the experimenter and sample as the first priority by applying sensor for temperature control and for anti-overheating circuit.
- The special insulation applied to the product will suppress the overheating thereof and will minimize the surface heat of main unit of the product.
- The magnet of strong magnetism embedded in the product and "Slow Start function" can prevent the springing of Stirring Bar and can support the agitation of specimens of high viscosity.
- The product can control the speed of operation precisely and thereby it can provide users with consistent performance of agitation.
- The wide display was furnished for the product to enable users a convenient checking on current range of set values for the operation of the product.

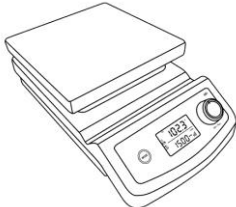
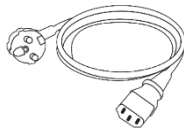
- The touch buttons were made by an excellent design focused on the convenience of users and maintenance thereof.
- The timer installed in the product will enable users to set the duration of the operation of the product up to 99 hours and 59 minutes.
- The product is furnished with functions capable of protecting the overheating, overcurrent, and sensor errors of the product to secure the safety of users.
- The mounting position for an external probe is also provided in the main unit of the product.

3. PRODUCT INSTALLATION

Composition identification

| Basic Components | | Qty |
|--|---|--|
| 1 |  | Hotplate Stirrer, Hotplate or Magnetic Stirrer Unit 1 |
| 2 |  | Power Cable 1 |
| 3 |  | Operating Manual 1 |
| Additional components for External Temp Probe Set (SH-HSD-Set) | | Qty |
| 1 |  | Stand Rod 1 |
| 2 |  | Temp Probe 1 |
| 3 |  | Sensor Holder 1 |
| 4 |  | Clamp 1 |
| 5 |  | Clip 2 |

How to install

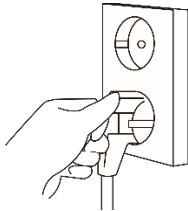
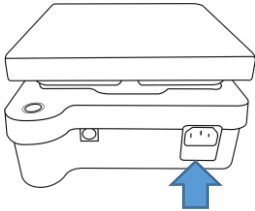
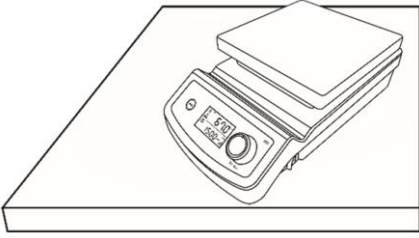

- ① Remove the packaging of the product at the place in which the floor of the interior is flat and the horizontality is maintained and place it on the designated place.
- ② Recommend that the product keeps a certain distance with other products. As the heat is generated by operating the product for long time, do not arrange the wall or other products near the product.
- ③ Confirm whether or not the power cable which is supplied together with the product is damaged and connect it with the product.
- ④ Insert the socket in the other side into the wall plug. In case of using a power strip, be careful not to exceed the electrical energy of maximum sum.
- ⑤ The ambient temperature may rise by the continuous high-temperature operation of the product thus users should put things vulnerable to heat away from the product.

* How to install the External Temperature Probe Set *

Users purchased the Package Set of this product should check the list of components therein. On occasions of purchasing the optional accessories of the product, be sure to check corresponding components to determine pertinent items.

The components are as follows.

- Direct contact Temperature Probe, Probe Ø4 X L250mm, Cable L190mm.
- Stainless steel Stand Rod, Ø10 x L450mm
- Holder + Clamp + Clip

- ① Locate the Stand Rod Hole in the main unit of the product and then mount the Stand Rod into the found Hole.
- ② Mount the Clamp on the Stand Rod in the direction same with that illustrated in the picture. Then, fix the Clamp to the proper position firmly by using the fixing knob.
- ③ Mount the Probe Holder onto the Clamp in a way the part of the longer diameter thereof facing upward. Fix the mounted Probe Holder to the proper position firmly by using the fixing knob.
- ④ Put the container with the specimen on top of the plate.

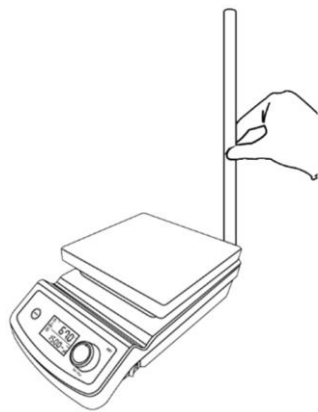

<Picture ①>

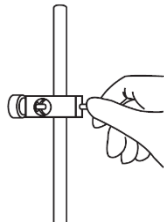

<Picture ②>

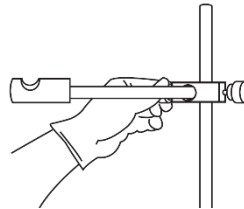

<Picture ③>

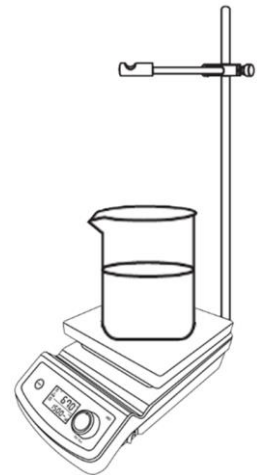

<Picture ④>

- ⑤ Insert the Temp Probe from above the Holder to mount it thereon. Then adjust and fix the position of the Holder inside the container of specimens in a way that the Temp Probe is fully immersed therein by using the fixing knob of the Clamp.
- ⑥ Fix the Probe Cable to the Rod by using the Clip so that the Probe Cable does not touch the heating upper plate.
- ⑦ Connect the Probe Connector located on backside of the product.

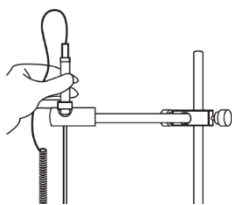

<Picture ⑤>



<Picture ⑥>

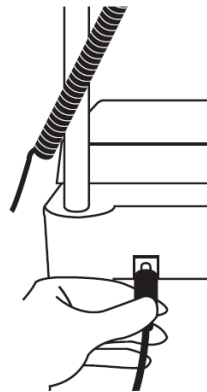

<Picture ⑦>

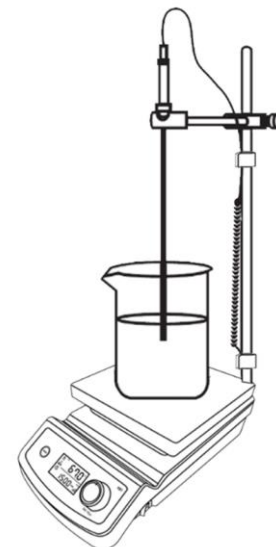

<Complete>

Product specification

4. Check before operation

Product structure

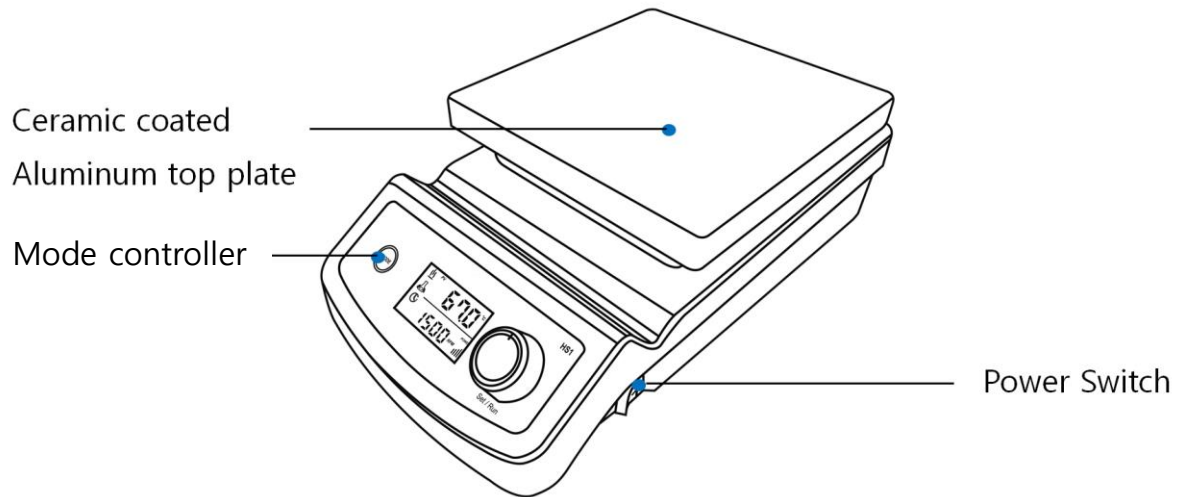

- Power Switch : Equipment power ON/OFF
- Mode controller : Controlling and checking of the operation.
- Ceramic coated Aluminum top plate : Heating and stirring operation.

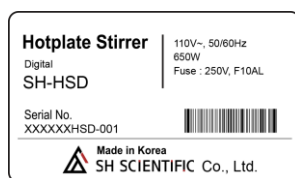
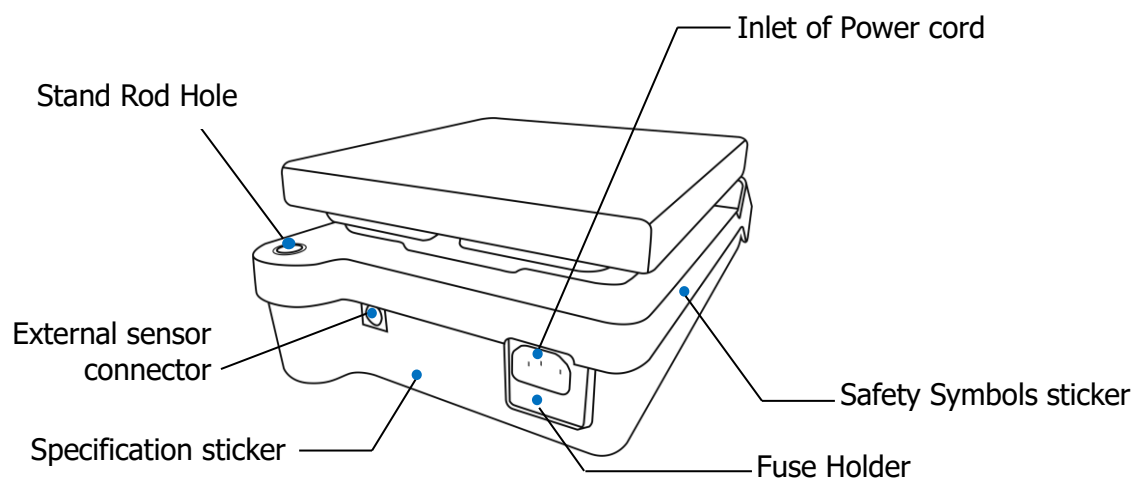



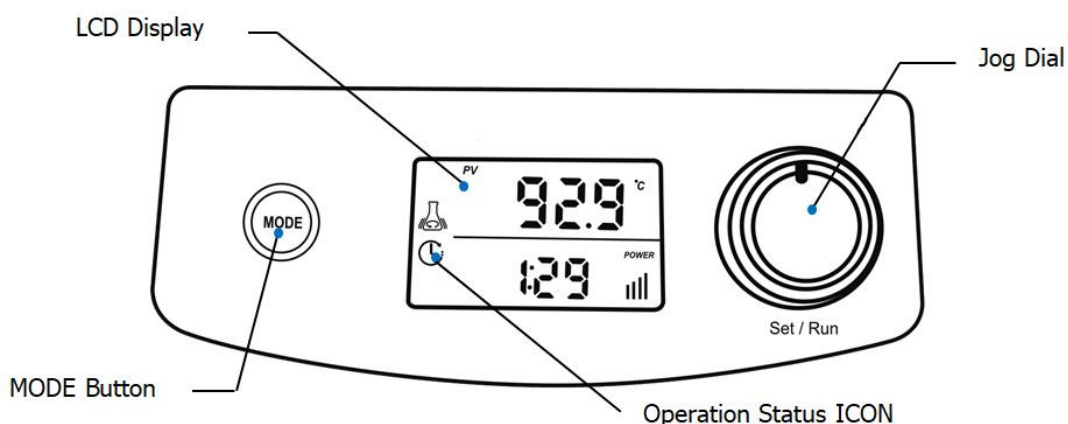

- External sensor connector : Connection piece of External sensor
- Specification sticker : Recording the specification and serial number of product.
- Fuse Holder : Fixing the fuse and protection not to expose.
- Stand Rod Hole : Stand Rod mounting parts.

Control panel



- MODE Button : Mode change button.
(RPM setting mode, Temperature setting mode, Timer setting mode, Locking mode)
- Push the MODE Button over 2 seconds to the Locking mode.
- LCD Display : Display operation information.
- Jog Dial : Turn clockwise or counterclockwise to adjust the setting value,
- Push the Jog Dial once to START/STOP the operation,
- Push the Jog Dial for 2 to 3 seconds to save the setting value.



* Operation Status ICON

| ICON | Stop Status | Running Status |
|---|---|-------------------------|
|  | Blinking at Setting Operation Temperature Mode. Off at the other mode. | On at heating power on. |
|  | Blinking at Setting RPM Mode. Off at the other mode. | Always On |
|  | Blinking at Setting Timer Mode. Off at the other mode. | Always On |
|  | On in error status / Off in normal operation | |



5. OPERATION

- Confirm whether the power cable is normally connected or not.
- Press the power switch which is positioned at the right side of the product.



Setting RPM

| Controller | How to operate |
|--|---|
|  | <ol style="list-style-type: none"> ① The display for the setting of RPM will appear initially. Users can see the unit of RPM on the display. ② The figures displaying on PV are the values of the RPM of current operation whereas the figures displaying on SV are the values of set RPM. |
|  | <ol style="list-style-type: none"> ① Turn the Jog Dial in the controller clockwise or counterclockwise to adjust the set values thereof then the agitation of the product will be initiated simultaneously. The range of set values spans from 80 rpm to 1,500 rpm and the set values will vary by the unit value of 5 rpm. ② If the set stirring speed is 0 RPM, Start operation is applied through the Turning of the Jog Dial, and if the setting value of the stirring speed is above 80 RPM, the value is changed by Turning of the Jog Dial and the START operation is performed by the Push button. ③ If turning the Jog Dial to counter-clockwise during the stirring operation, the operation can be stopped by reducing the speed value or by setting it to 0 RPM, or the Stop operation can be carried out by the Push button of the Jog Dial. ④ Push the Jog Dial for 2~3 seconds, then the set value of RPM will be blinking and be stored thereby. The stored value of RPM that remaining unchanged will be reappearing by the next turn-on of power supply. ⑤ The POWER rod bar of the Display represents the stirring power, and it is displayed at all times during the stirring operation. The stirring power is automatically controlled to match the setting RPM according to the viscosity of the sample. |



Setting Operation Temperature

| Controller | How to operate |
|---|--|
|  | <ol style="list-style-type: none"> ① Click the MODE button in the display of setting values of RPM, then the display will be changed into setting values of the operation temperature. ② The figures displaying on the PV correspond to the value of current temperature whereas the figures displaying on the SV are the values of set temperature. |
|  | <ol style="list-style-type: none"> ① Rotate the Jog Dial clockwise or counterclockwise to adjust the set values. The values available for the set temperature ranges from 25.0°C to 400.0°C and the set values will be varying by the unit value of 0.5°C. ② Push the Jog Dial once and shortly, then the product will start the heating operation to the set temperature. ③ Push the Jog Dial once shortly in the display of setting of operation temperature during an operation of the product, then the product in its heating operation will stop thereby. ④ Push the Jog Dial for 2~3 seconds, then the set value will be blinking and be stored thereby. The stored value that remaining unchanged will be reappearing by the next turn-on of power supply. ⑤ If the external sensor is not connected, the temperature of the top plate is displayed. When connected an external sensor, the temperature measured by the external sensor is displayed on the display. If an external sensor is connected to the product by putting it in solution, the temperature of the solution is displayed on the product. <ul style="list-style-type: none"> ● When it is connected with external temp. sensor, it needs a few seconds for stable temp. value on display. |

Setting Temperature Offset

| Controller | How to operate |
|---|--|
|  <p>The image shows a digital display with a flame icon on the left. The top part is labeled 'PV' and shows '37.8 °C'. The bottom part is labeled 'SV' and shows '00 °C'.</p> | <ol style="list-style-type: none"> ① Offset value is the function that can add or reduce the constant value by setting the compensation value in the case that user must experiment by matching the thermometer which he/she is using as the experimental standard and the thermometer indicated in this regulator. ② Offset setting screen can be changed by holding down the MODE button on the temperature setting screen and briefly pressing the Jog Dial once, and releasing the MODE button. |
|  <p>The image shows a digital display with a flame icon on the left. The top part is labeled 'PV' and shows '37.8 °C'. The bottom part is labeled 'SV' and shows '10.0 °C'.</p> | <ol style="list-style-type: none"> ① The scope of the compensative value is $-20.0^{\circ}\text{C} \sim +20.0^{\circ}\text{C}$, and it is possible to adjust at 0.1°C unit. ② After setting the compensation value, the indication of the current temperature is displayed as the temperature including the compensation value. ③ On entering into the mode of the setting up of corrected value of set temperature during an operation of heating, then the heating operation of product will stop. On the completion of resetting the set temperature with corrected value, the product will resume the heating operation, and this will be appearing in the display of setting values for the heating temperature. ④ Push the Jog Dial for 2~3 seconds, then the set value will be blinking and be stored thereby. The stored value that remaining unchanged will be reappearing by the next turn-on of power supply. ⑤ If pressing Mode button, it is switched to the Temperature setting screen. |

Setting Timer

| Controller | How to operate |
|---|---|
|  <p>The image shows a digital display with two rows. The top row is labeled 'PV' and shows ': 0'. The bottom row is labeled 'SV' and shows ': 0'. There is a clock icon to the left of the 'SV' label.</p> | <ol style="list-style-type: none"> 1. Click the MODE button in the display of setting values of operation temperature, then the display will be changed into the display of setting values of the timer. 2. The figures displaying on PV represent the remaining time determined by the timer whereas the figures displaying on SV represent the time set by the timer. |
|  <p>The image shows a digital display with two rows. The top row is labeled 'PV' and shows '99:59'. The bottom row is labeled 'SV' and shows '99:59'. There is a clock icon to the left of the 'SV' label.</p> | <ol style="list-style-type: none"> 3. Rotate the Jog Dial clockwise or counterclockwise to adjust the set values of the timer. The range of values of the time set by the timer can be up to 99 time and 59 minutes and the set value will be varying by a unit of 1 minutes. 4. Push the Jog Dial once and shortly, then the product will start the timer operation. 5. Push the Jog Dial once shortly in the display of setting of timer during an operation of the product, then the product in its timer will stop thereby. 6. When the value of timer is set 0, then the product will operate with set value continuously. In the case of entering the timer value into the product, then the product will stop its operation of heating and automatic agitation with an alarm on the expiry of the set value of timer. 7. Push the Jog Dial for 2~3 seconds, then the set value of timer will be blinking and be stored thereby. The stored value of timer that remaining unchanged will be reappearing by the next turn-on of power supply. |

Locking MODE

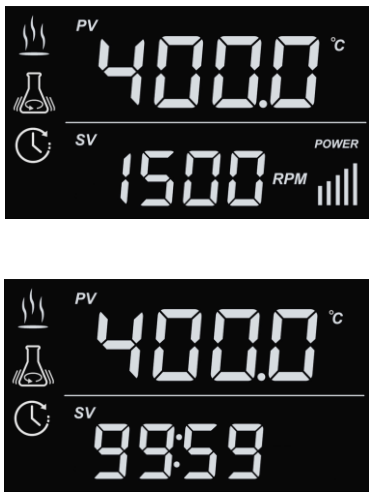
| Controller | How to operate |
|---|--|
|  | <ol style="list-style-type: none"> ① In every mode, when pushing the MODE button for 2~3 seconds, then the display will be changed into the display of locking mode. ② Accelerating and stop right after the locked display will prevent potential risks of malfunctioning of the product due to unintended turning of Jog Dial or disabled application of push button. Besides, the current temperature, current stirring speed and remained timer value of operation will be displayed thereon together for users' convenience. ③ Upper level LCD will show present temperature and lower level LCD will show RPM. ④ When it works stirring with timer, RPM and Timer value will be displayed alternately on lower level LCD. ⑤ When pushing the Mode button for 2~3 seconds in Locking MODE, Locking MODE will be released and then last set mode will be shown. |

6. Maintenance

Regular inspection

| Classifications | A period of checking time | | |
|--|---------------------------|------|-------|
| | Day | Week | Month |
| Connection state of the source of electric power | √ | | |
| Damage of power cable | √ | | |
| Cleaning state of power cable | √ | | |
| Accessory assembly status | √ | | |
| Cleaning state of the Controller | √ | | |
| Cleaning state of the body | | √ | |
| Shape preservation of rubber foot | | √ | |
| Cleaning state in top plate | | √ | |
| Normal Control of Operation Mode | | √ | |
| Normal Control of Adjusting Knob | | √ | |
| Damage state of fuse | | | √ |

How to replace the fuse

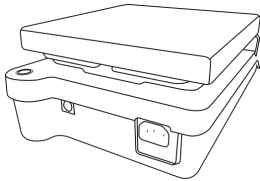
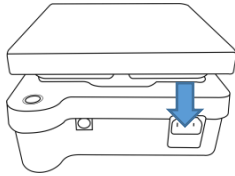
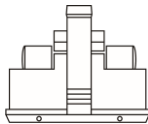
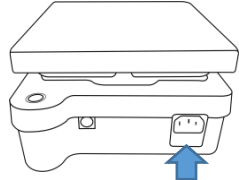
| | | | |
|---|---|--|---|
|  |  |  |  |
| Separate the power cable in the back side of the product, and identify the fuse holder. | Separate the holder from the body using a flat-tip screwdriver. | Identify the fuse and replace it. | Re-assemble the holder again. |

Cleaning and storage

● Cleaning of the product

Maintain the cleaning state of the product by regular cleaning. The regular maintenance of the product extends the life time of the product and minimizes the contamination of specimen.

- ① Confirm whether or not any foreign matters exist, and if yes, immediately wipe off them.
- ② Do not use abrasive or detergent based on solvent.
- ③ If a chemical substance stains the product, wear gloves and a mask which are composed of chemical resistance material and wipe off them with a piece of dry cloth.
- ④ Before cleaning the product, you must separate the power cord from the body.
- ⑤ For the part from which the contaminant is not easily erased, wipe off only the part with the towel wetting with the solvent that has low freezing point.
- ⑥ Keep the ceramic upper plate clean. And clean the ceramic upper plate by using non-abrasive cleaner.
- ⑦ If the materials wetted by liquid or water are entered into this product, please immediately stop the operation and disconnect the power of the product.
- ⑧ Please use the stirring bar with the suitable size and shape in order to provide optimum performance.
- ⑨ Do not use the container made of metal. Metals may or potentially trigger abnormal heating of the product. Metals may also damage the ceramic upper plate.

● Disposal of the product



- When the warranty period of the product is terminated, it should be disposed in accordance with the management regulation of wastes of the corresponding territory.

● Storage of the product





- ① If the product is not used for long time, separate the power socket from the body, wrap and store it.
- ② Store them in the same place not to lose the components.

7. Troubleshooting

Error identification

| Problem | Possible Causes | Corrective Action |
|--------------------------------|--|---|
| ERROR 1 | <ul style="list-style-type: none"> • Problems of Abnormal Heating and Abnormal Display of Set Temperature Value. | <ol style="list-style-type: none"> ① If an external sensor is connected, make sure that the external sensor is correctly connected. ② Expose the external sensor to the air and confirm that the product is operating. In this case, the sensor may fail. ③ If the problem is not solved, contact our customer service. |
| ERROR 2 | <ul style="list-style-type: none"> • Problems of Operating at Abnormal Speed and Display of RPM | <ol style="list-style-type: none"> ① Make sure that there are no obstacles to the rotation of the stirring motor. ② If the problem is not solved, contact our customer service. |
| In case of failing to operate. | <ul style="list-style-type: none"> • Power supply which is not met with the electric power voltage of the product • Switch-off of the residual-current device at the installation place or occurrence of power failure • Inaccurate connection between a power plug and a socket • Damage of socket/plug/power cable • Disorder of either embedded sensor or controlling device. • Short-circuit of fuse • Status of Locking Mode | <ol style="list-style-type: none"> ① Confirm whether the power switch is ON or not. ② Confirm whether power failure occurs or not. ③ Connect the power plug to the wall socket accurately. ④ If the short-circuit of fuse occurs, replace it. ⑤ Check if the push button of Rotary Switch has been pressed correctly to operate the product at the set value. ⑥ If the problem is not solved, contact our customer service. |

8. Optional accessory

| Component | Ordering Number | Information |
|---|-----------------|---|
|  | SH.HSTP | <p>"HSTP" Direct contact Temperature Probe, Probe Ø4 X L250mm, Cable L190mm.</p> |
|  | SH.HSTTP | <p>"HSTTP" Direct contact Teflon Coated Temperature Probe, Probe Ø4 X L250mm, Cable L190mm.</p> |
|  | SH.HSSR | <p>"HSSR" Stainless steel Stand Rod, Ø10 x L450mm</p> |
|  | SH.HSHC | <p>"HSHC" Holder + Clamp + Clip</p> |

■ Free warranty service

If any malfunction due to the flaw of the product occurs within 2 years from the purchasing date, the product is free repaired or replaced it with the same kind product after inquiring our office or dealer.

■ Onerous service

- In case after a lapse of warranty service period of 2 years. In case the product is arbitrarily remodeled or repaired.
- In case the malfunction by natural disaster. (fire, damage of sea water, gas disaster, flood damage and so on).
- In case the malfunction occurs by not observing the safety caution and warning described in the user manual.
- In case the malfunction occurs by the handling carelessness of the user.