

CVO-10 PRO PACKAGE

- 10 CUBIC FT OVEN SPACE
- MOBILE FOOT PRINT
- OPTIMIZED PURGE CONNECTIONS
- NRTL CERTIFIED

Ideal for large volume production with massive shelf surface area.

Powered by Agilent's IDP15-9 cfm oil free scroll pump. Clean, Quiet, Powerful.

PACKAGE INCLUDES

- CVO-10 Vacuum Oven
- 9 Total Shelves - 28"W x 24"D
- Agilent IDP15-9 CFM Scroll Pump
- Industrial Mobile Rack
- MAXEVAP KF-25 Connection for faster purge

FEATURES

Temperature probe INSIDE oven for accurate readings

Power vacuum pump from control panel (220V)

Reduced purge times with the full KF-25 port plus MAXEVAP connections

Bright LED lights & tempered safety glass viewing window

Touchscreen microprocessor control

Digital vacuum gauge

Solvent resistant BUNA-N door gasket

Top-quality, easy turn valves

Shelves pull-out and stay in place on sliders

Large 1/2" vent lines for faster venting

Easy nitrogen backfill connection



LARGE CAPACITY VACUUM PURGE SYSTEM

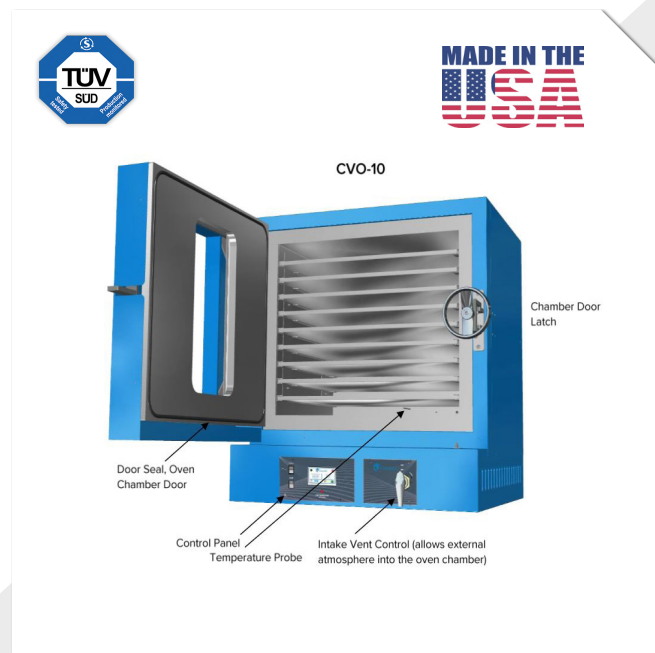

Visit our showroom!
6725 NE Evergreen Pkwy, Ste 106
Hillsboro, OR 97124



(503) 847-9047
info@cascadesciences.com
cascadesciences.com
© 2018 Cascade Sciences, LLC

REV 6/18

SPECIFICATIONS



NRTL CERTIFICATION

CAN/CSA-C22.2 No. 61010-1:2012
+ UPD No. 1:2015-07 + UPD No. 2:2016-04

CAN/CSA-C22.2 No. 61010-2-010:2015

UL 61010-1:2012/R:2016-04

UL 61010-2-010:2015

EN 61010-1:2010



CVO-10 VACUUM OVEN

CAPACITY

Volume: 9.3 Cubic Ft/264 liters
Interior: 28"W x 24"H x 24"D

SHELVING

9 Each. Fixed. Sliding. Removable. 9 Max

Surface Area: 28"W x 24"D
Weight Capacity: 50 lbs

TEMPERATURE

Stability: $\pm 0.4^\circ$ @ 105°F / 40.5°C
Uniformity: $+1.5^\circ$ @ 105°F / 40.5°C
Low Temp Range: to 250°F / 121°C

CONNECTIONS (INCLUDED)

Vacuum: KF-25, 1" Lines, 1" Valve
Vent: 1/2" barb
KF-25 Port (1" Dia) YES (1" Dia)

WEIGHT

Oven/Pump: 663 lbs / 75 lbs
Shipping: 1119 lbs

NRTL CERTIFICATION

IEC 61010-1:2010 / EN 61010-1:2010

Canada: CSA C22.2 No. 61010-1-12

USA: UL Std. No. 61010-1 (3rd Edition)

EN 1012-2:2009 EN 12100:2010



AGILENT IDP15 SCROLL PUMP

PERFORMANCE

Pumping 9cfm
Speed at 60Hz: 213 L/m, 12.8 m3/hr
Ultimate Pressure: 10×10^{-3} Torr (13.3×10^{-3} mbar)
Gas Ballast: 1/4" NPT
Position 1: 20.7 g/hr water vapor (installed)
Position 2: 235 g/hr water vapor

CONNECTIONS (INCLUDED)

Inlet: KF-25
Exhaust: KF-16

DIMENSIONS

19.2" D x 14.33"H x 9.5"W

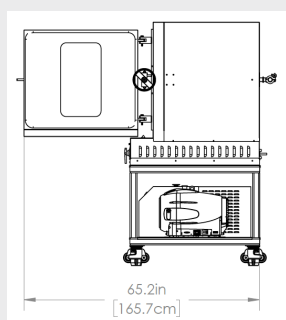
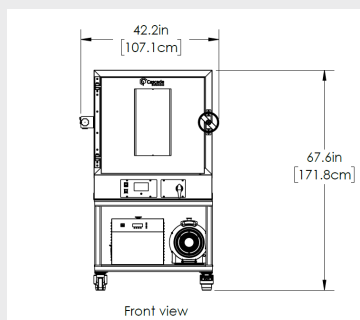

*will not fit through a standard 36" doorway

FACILITY SPECIFICATIONS RECOMMENDED SYSTEM CIRCUITS

2 each 220V / 1pH 20AMP

Optional: 1 each 120V / 1pH for future cold trap, ancillary equipment or to run pump on 120V

CVO-10 VAC OVEN

220V-240V / 1pH / 10 FLA

(System will run on 208V)

AGILENT IDP15 PUMP

220V-230V / 1PH / 3AMP

120V / 1pH / 5AMP

*m/sec AMP surge at start up



220-240V AC
Turn Lock, NEMA L6-15 Plug

Noise Level:

50dBA +/- 2dBA

Operating Temp:

41°F-104°F / 5°C-40°C

Visit our showroom!

6725 NE Evergreen Pkwy, Ste 106
Hillsboro, OR 97124



(503) 847-9047

info@cascadesciences.com

cascadesciences.com

© 2018 Cascade Sciences, LLC